

Hydraulic actuator type Z for Herzog® shut-off nozzles

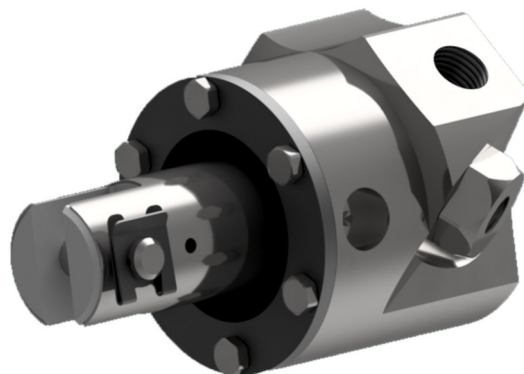

Applications:
Herzog® shut-off nozzles

Index of contents

Chapter	Page
Safety instructions	2
Servicing the hydraulic actuator type Z	
Disassembly	3
Assembly positions	3
Installation	4
Parts subject to wear / ordering spare parts	5

Safety instructions



This symbol indicates explanations about important matters. Failure to read these or false handling could result in injury or damage.

Please pay attention to the following safety instructions and precautions



Handling

- Installation and servicing to be only carried out by protected personnel according to the installation and service instructions.
- Actuator can become extremely hot. Full face protection and heat resistant gloves must be worn.



Damage precaution

- Do not drop the actuator or exert it to unnecessary forces.
- Take care that no foreign bodies enter the working parts of the cylinder.
- No adjustment or manipulation when nozzle is in operation.
- The actuator is designed for temperatures up to **180°C**.
- Actuator is only to be used for injection molding purposes.



Operational notes

- Torques on screws and threaded parts must be adhered to.
- Noise emissions from the nozzle do not exceed 70 dB(A).



Keep this manual in a convenient place for future reference.

Servicing the hydraulic actuator

Disassembly type Z

⚠ Read safety instructions!

Our actuator does not normally require servicing. Only after extreme operating conditions it may be necessary to clean the actuator or replace seals.

- Remove seals carefully
- Screws with adhesive should be carefully heated before loosening
- Never heat the actuator above 180°C!
- Check all parts for wear

Seal fitting

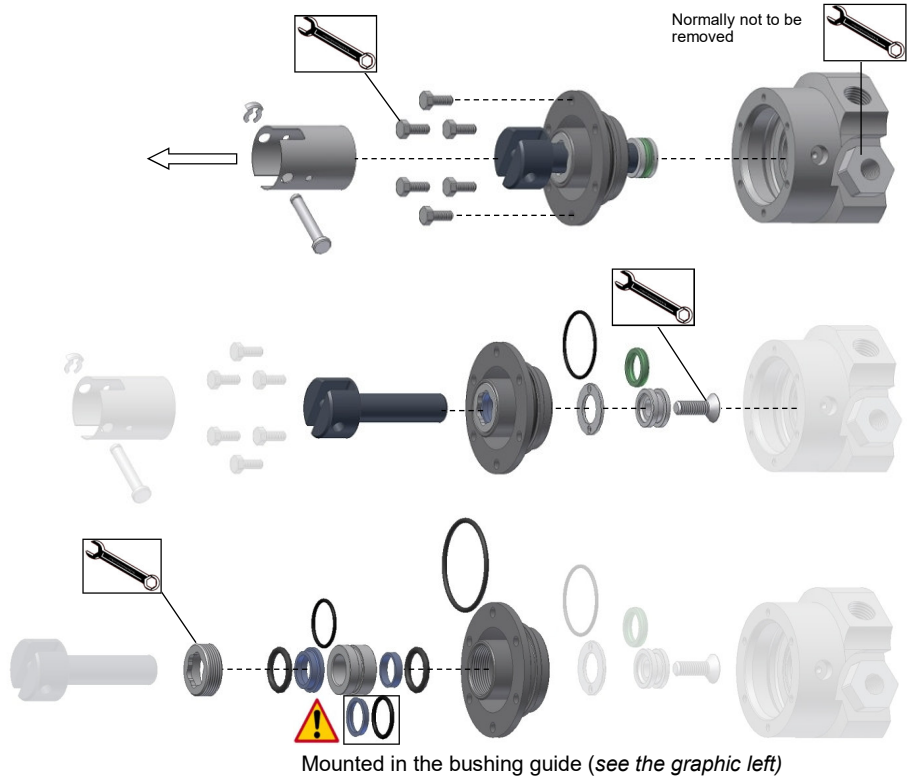
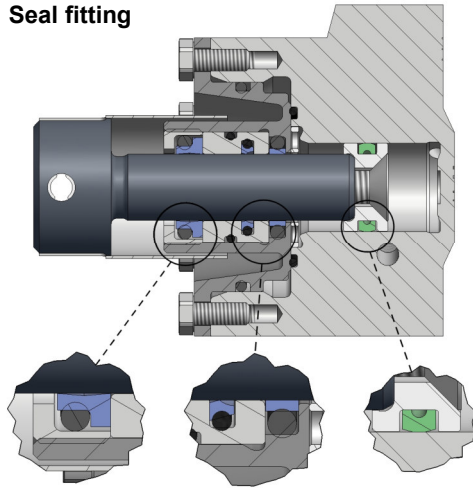

Assembly positions type Z (Read also installation instructions!)

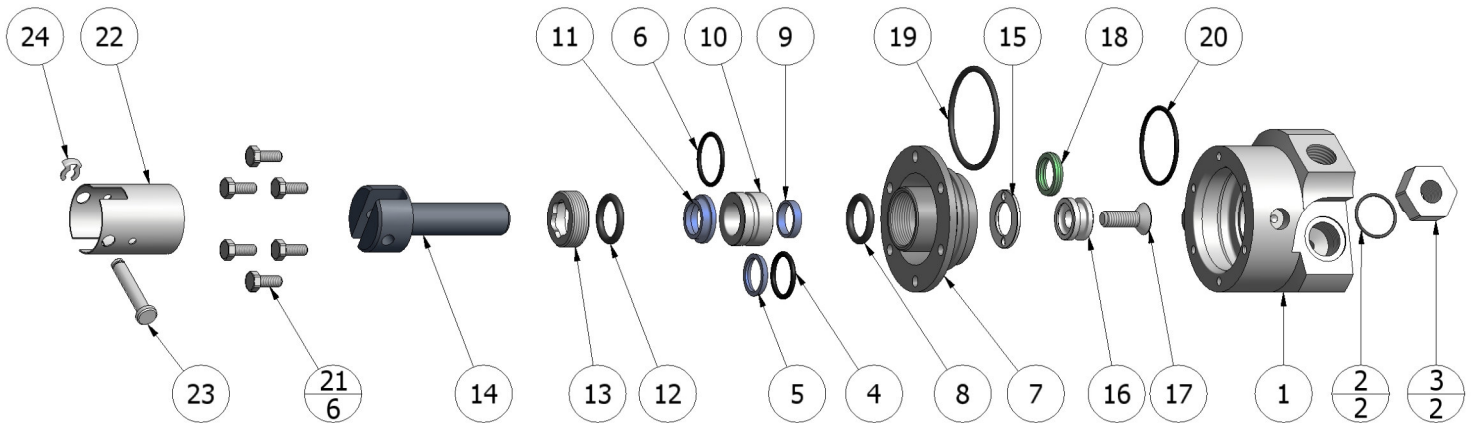

Pos.	Description	Actuator size Z0	Actuator size Z1	Actuator size Z2	Actuator size Z3	Note
1	Actuator housing					
2, 4, 6, 8, 12, 19, 20	O-ring					Apply some grease
3	Reducing adapter	AF19 / 50Nm	AF19 / 50Nm	-	-	Secure with adhesive
5	Piston rod seal					
7	Guide housing					
9	Seal ring					
10	Bushing guide					
11	Wiper ring					
13	Locking screw	AF12 / 20Nm	AF12 / 20Nm	AF12 / 20Nm	AF16 / 30Nm	Secure with adhesive
14	Piston rod					
15	Stop disk					
16	Piston					
17	Screw	4mm key / 9Nm	AF10 / 14Nm	AF13 / 25Nm	AF17 / 60Nm	Secure with adhesive
18	Piston seal					
21	Screw	AF7 / 6Nm	AF7 / 6Nm	AF7 / 6Nm	AF10 / 14Nm	Use screw grease
22	Dirt cover					
23	Bolt					
24	Clip					

Installation instructions

- Clean and inspect all parts for damage
- Grease threads with high temperature paste (bis 180°C)
- Pay attention to parts requiring temperature resistant adhesive
- High temperature seals required (200°C)

Profit from our cleaning service. The actuator is taken apart, checked and repaired if necessary.

Installation actuator type Z

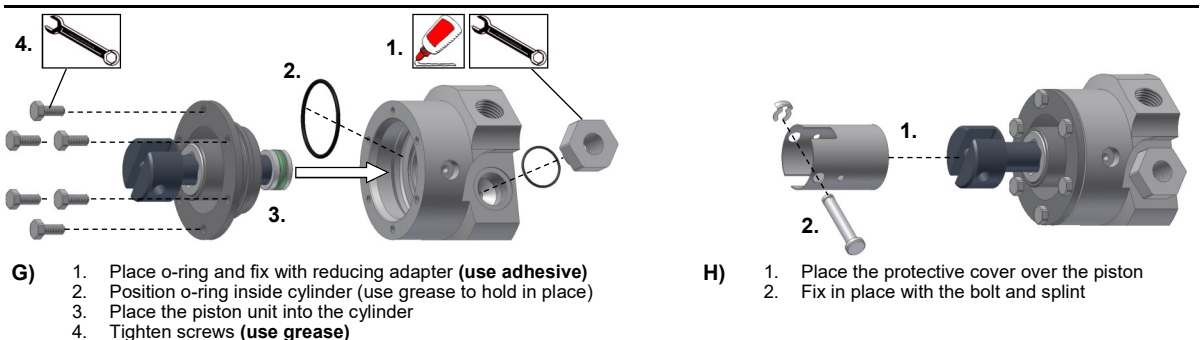
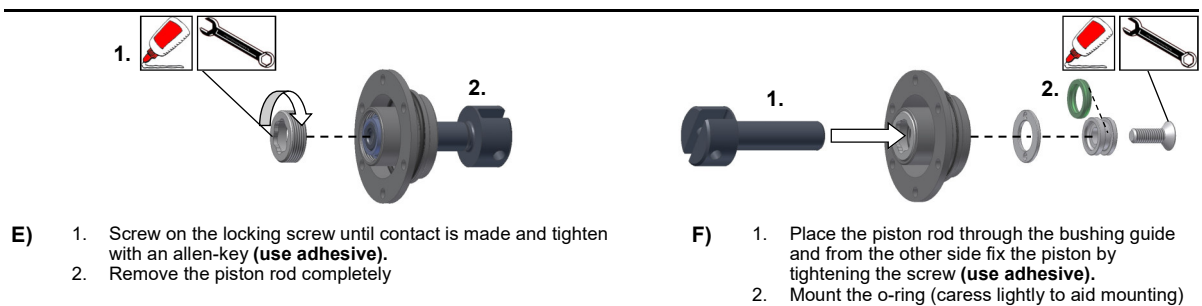
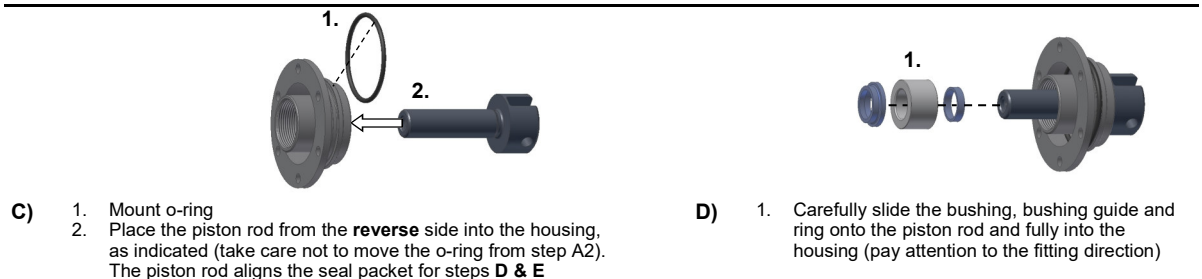
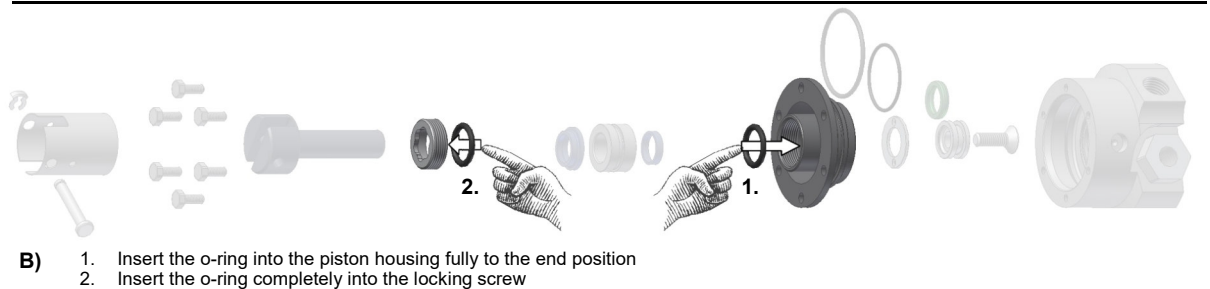
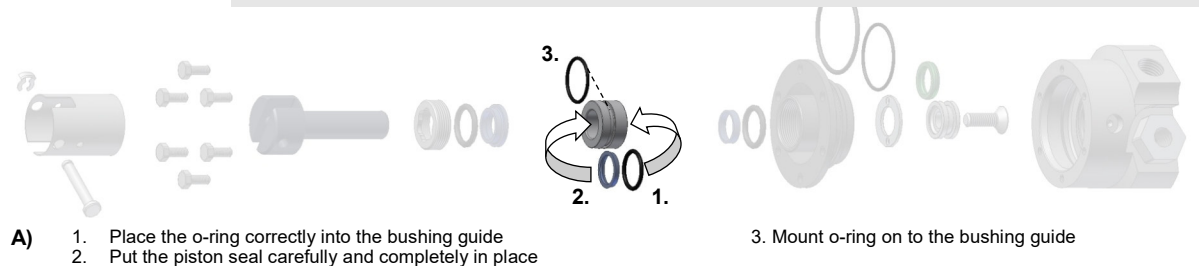

Parts subject to wear / ordering spare parts

Your contact information:

Company	
Street	
City / Zip	
Contact	
Tel. / Fax	
E-Mail	

Lasered cylinder identity no.: please insert here

--

Lasered nozzle identity no.: please insert here

--

Quantity	Part (for part name, see chapter Assembly)

Send to:

herzog systems ag
CH-9230 Flawil / Switzerland

Tel. +41 (0) 71 394 19 69 / Fax +41 (0) 71 394 19 60
www.herzog-ag.com / info@herzog-ag.com